

PROACTIVE ENVIRONMENTAL PRODUCTS-PROACTIVE PUMPS



For even deeper wells, ProActive introduces the Hurricane. The Hurricane is capable of pumping up to 150 feet from ground level by simply connecting the pump to our revolutionary Low Flow With Power Booster II Controller, or Power Booster II Controller (controller sold separate).

Note: These controllers increases 12 volts to a constant 24 volts.

In return, the Hurricane will make your next groundwater sampling event go much quicker when it comes to purging a well. And with the Low Flow With Power Booster II Controller, the field technician now has the ability to control the flow of water being discharged from the Hurricane thus, keeping up with EPA groundwater standards for Low Flow Sampling.

The Hurricane's reliable design is suitable for continuous sampling or purging of groundwater wells.

Simplify and Expedite Your Next Sampling Event!

The Hurricane can pass sand, small rocks and debris without getting clogged or damaging the pumps motors!

The Hurricane can run continuously without the need for a cool down!

The Hurricane can also run dry for up to 2 hours without motor damage!

The Hurricane has a 400 hour motor life!

The Hurricane has a sleek outside that minimizes well hang-ups.

The Hurricane is a very reliable and economical pump that provides a great bang for your buck!

The Hurricane comes ready for field use; For your convenience the Hurricane comes complete with a sturdy polymer reel along 160 feet of heavy duty wire and Power Booster II adapter and it is shipped in its own box.

SPECS:

POWER CONSUMPTION:	360 WATTS (MAX)
VOLT RECOMMENDATION:	12-15 At Source
MAXIMUM AMP OUTPUT:	15 AMPS
MEASUREMENTS:	LENGTH 24" / DIAMETER: 1.8"
CONSTRUCTED:	PVC PLASTIC & STAINLESS STEEL
DISCHARGE OUTLET:	3/8" ID x 1/2"ID (WITH BARBED TIP ENLARGER)
SUPPLIED WITH:	160 FEET OF HEAVY DUTY 10 GAUGE WIRE, WITH THREE PRONG MALE ADAPTER AND MOUNTED ON A HIGH IMPACT PLASTIC REEL

PROACTIVE ENVIRONMENTAL PRODUCTS-PROACTIVE PUMPS

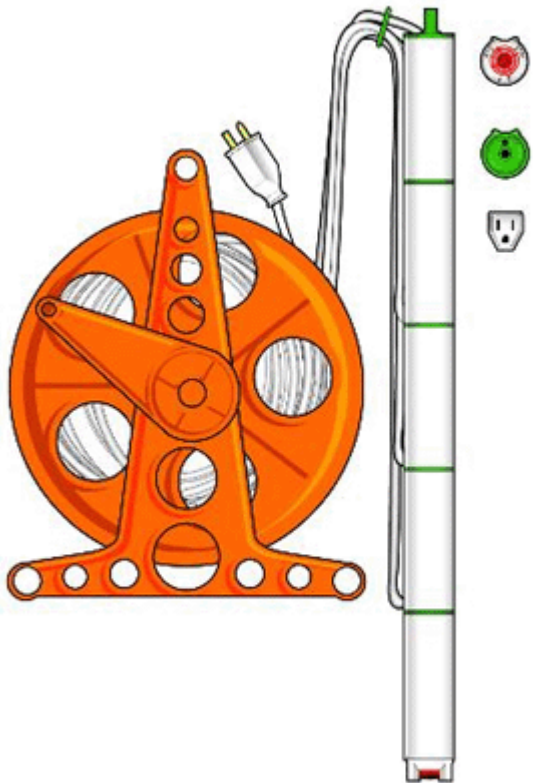

Hurricane Pump Chart

PUMPING DEPTH (DTW)	GALLONS PER MINUTE
3	4.70
10	4.50
20	4.00
30	3.50
40	3.00
50	2.75
60	2.50
70	2.25
80	2.00
90	1.75
100	1.35
110	1.25
120	1.15
130	.75
140	.50
150	.25
160	N/A